

Typical Performance

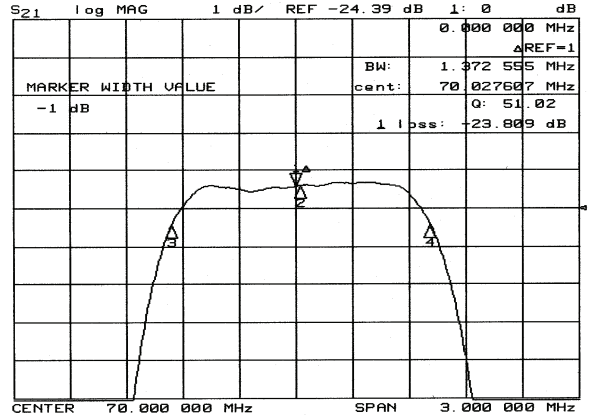
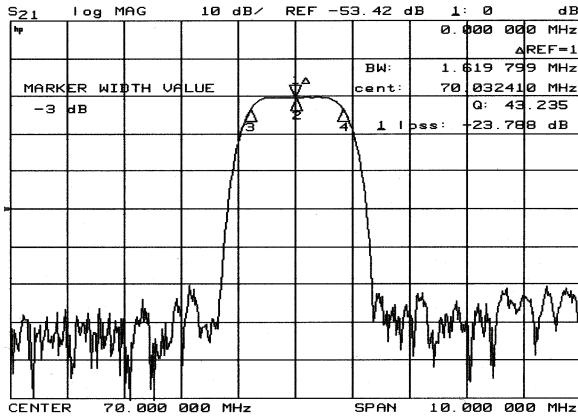

Specification

Index	Unit	Min	Typical	Max
Center Frequency	MHz	69.92	70	70.08
Insertion Loss	dB	-	23.5	25
1 dB Bandwidth	MHz	-	-	-
3 dB Bandwidth	MHz	1.5	1.6	-
40 dB Bandwidth	MHz	-	2.55	2.8
Passband Ripple	dB	-	0.35	0.7
Group Delay Variation	nsec	-	100	200
Absolute Delay	μsec	-	2.85	-
Ultimate Attenuation	dB	50	55	-
Substrate Material		Quartz		
Temperature Coefficient	ppm/°C	-0.03		
Package	mm	0		

Package Dimension

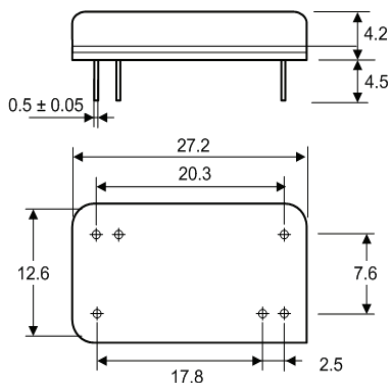

Matching Configuration

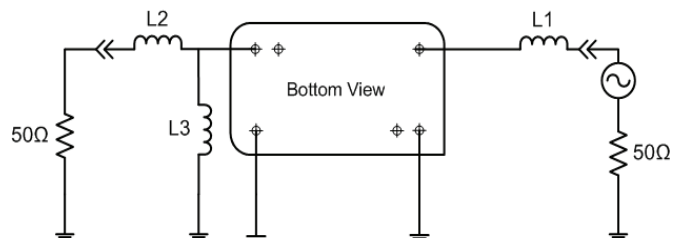

L1=L2=180nH, L3=220nH
 Source / Load Impedance = 50Ω
 Ambient Temperature = 25°C