

### Typical Performance

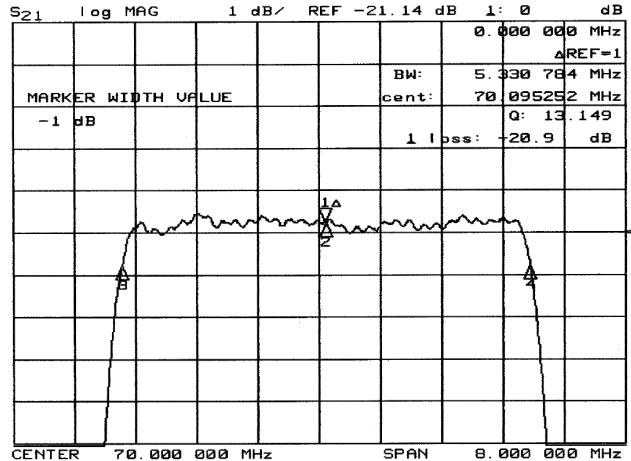
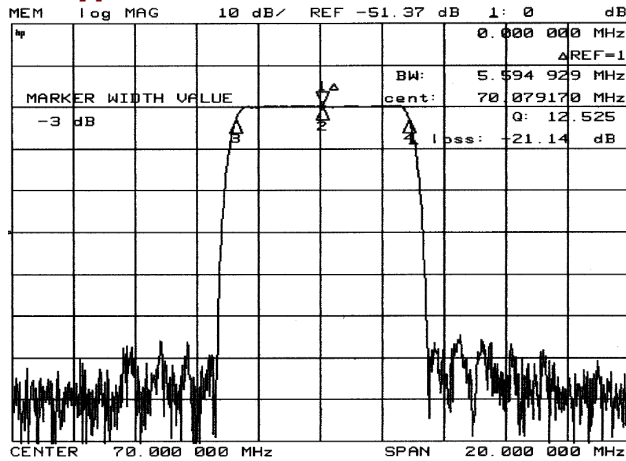

### Specification

Index	Unit	Min	Typical	Max
Center Frequency	MHz	69.92	70.00	70.08
Insertion Loss	dB	-	21.5	23.0
1 dB Bandwidth	MHz	5.20	5.35	-
3 dB Bandwidth	MHz	5.50	5.60	-
40 dB Bandwidth	MHz	-	6.75	7.00
Passband Ripple	dB	-	0.55	1.00
Group Delay Variation	nsec	-	150	250
Absolute Delay	µsec	-	2.89	-
Ultimate Rejection	dB	50	55	-
Substrate Material	-	YZ-LiNbO3		
Temperature Coefficient	ppm/°C	-94		
Package	mm	35		

### Package Dimension

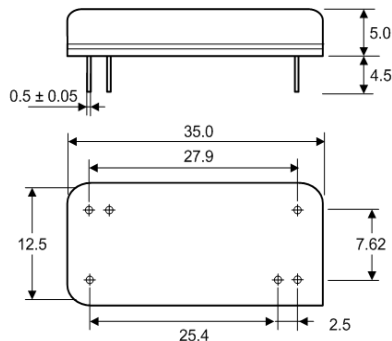

### Matching Configuration

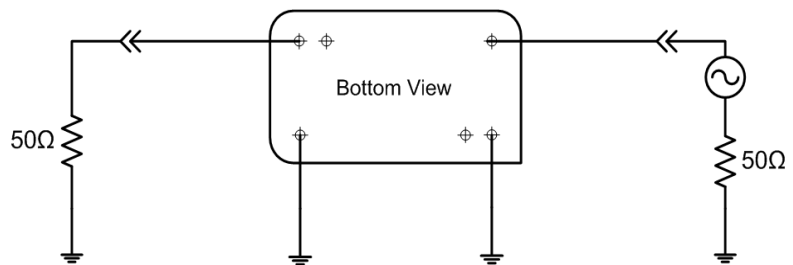

No matching required  
 Source / Load Impedance = 50Ω  
 Ambient Temperature = 25°C