

Typical Performance

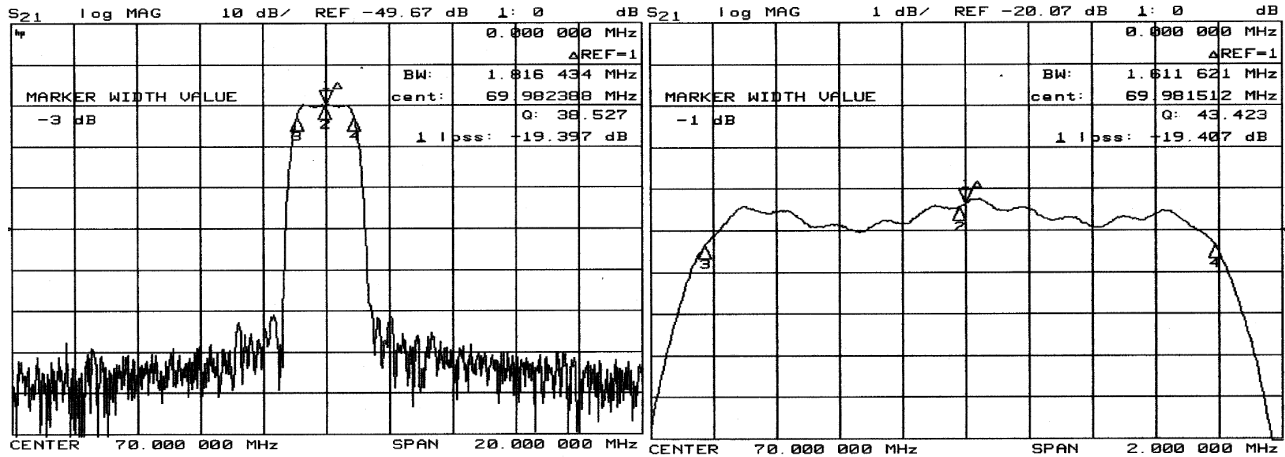

Specification

Index	Unit	Min	Typical	Max
Center Frequency	MHz	69.92	70.00	70.08
Insertion Loss	dB	-	19.5	21.0
1 dB Bandwidth	MHz	1.50	1.61	-
3 dB Bandwidth	MHz	1.70	1.81	-
40 dB Bandwidth	MHz	-	2.63	2.80
Passband Ripple	dB	-	0.85	1.00
Group Delay Variation	nsec	-	250	300
Absolute Delay	µsec	-	3.30	-
Ultimate Rejection	dB	50	55	-
Substrate Material	-	Quartz		
Temperature Coefficient	ppm/°C	-0.03		
Package	mm	35		

Package Dimension

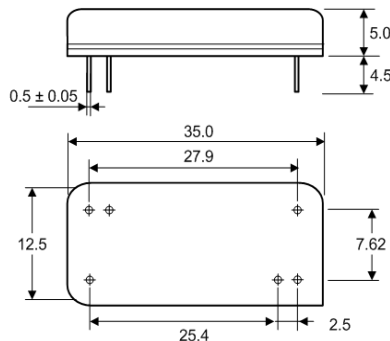

Matching Configuration

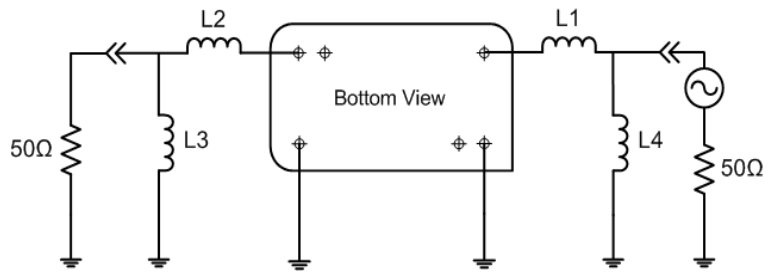

L1=L2=220nH, L3=L4=68nH
Source / Load Impedance = 50Ω
Ambient Temperature = 25°C